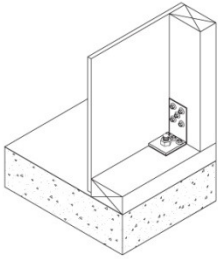
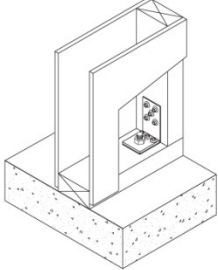
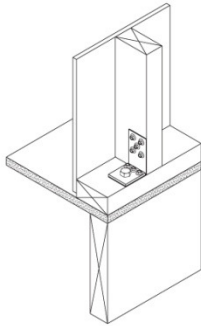
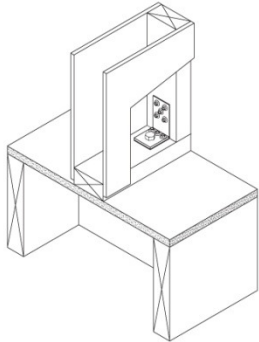

# GIB Handibrac®- Recommended Installation Method

December 2009

Developed in conjunction with MiTek™ NZ, the GIB Handibrac® has been tested for use as a hold down in all EP Bracing elements.

- The GIB Handibrac registered design provides for quick and easy installation
- The GIB Handibrac provides a flush surface for the wall linings because it is fitted inside the framing. There is no need to check in the framing as recommended with conventional straps.
- The GIB Handibrac is suitable for both new and retrofit construction
- The design also allows for installation and inspection at any stage prior to fitting internal linings

Concrete Floor		Timber Floor	
External walls	Internal walls	External walls	Internal walls
			
Position GIB Handibrac® as close as practicable to the internal edge of the bottom plate	Position GIB Handibrac® at the stud/plate junction	Position GIB Handibrac® in the centre of the perimeter joist or bearer	Position GIB Handibrac® in the centre of the floor joist or full depth solid block
Hold-down fastener requirements			
A mechanical fastening with a minimum characteristic uplift capacity of 15kN		12 x 150 mm galvanised coach screw	

Reproduced with the permission of Winstone Wallboards Ltd

Ecoply Bracing Systems are designed to meet the requirements of the NZBC and have been tested and analysed using the P21 method referenced in NZS3604:1999 listed as an acceptable solution B1/AS1 Structure. Testing was carried out using Ecoply®, Shadowclad® and Laserframe® MSG8 timber framing manufactured by Carter Holt Harvey® Woodproducts New Zealand, and GIB® products manufactured by Winstone Wallboards Ltd. Substituting materials may compromise performance of the system. GIB® and GIB Handibrac® are registered trademarks of Fletcher Building Holdings Ltd