

3.5 ECOPLY® BRACING SPECIFICATION – EPG

STRUCTURAL PLYWOOD BRACE WITH PLASTERBOARD OTHER SIDE

Specification No.	Minimum Wall Length	Lining Requirements	BU's/m Wind	BU's/m Earthquake
EPG	0.4 m	7 mm Ecoply® or 12 mm Shadowclad® one side and 10 mm GIB® Standard plasterboard other side	120	125
	1.2 m		150	150

Framing

Wall framing must comply with:

- NZBC B1 - Structure: AS1 Clause 3 Timber (NZS3604)
- NZBC B2 - Durability: AS1 Clause 3.2 Timber (NZS3602)

Framing dimensions and height are as determined by the NZS3604 stud and top plate tables for load bearing and non load bearing walls. Kiln dried verified structural grade timber must be used. Machine stress graded timber, such as Laserframe®, is recommended.

Bottom plate fixing

Use GIB HandiBrac® hold-down connections at each end of the bracing element. Refer to installation instructions supplied with the connectors for correct installation instructions and bolt types to be used for either concrete or timber floors. Within the length of the bracing element, bottom plates are fixed in accordance with the requirements of NZS 3604:1999.

Lining

Side 1: One layer 7 mm Ecoply structural plywood or 12 mm Shadowclad exterior wall cladding fixed directly to framing or over cavity battens. If part sheets are used, ensure nailing at required centres is carried out around the perimeter of each sheet or part sheet. A 2-3 mm expansion gap should be left between sheets.

Side 2: One layer 10 or 13 mm GIB® Standard plasterboard vertically or horizontally fixed. Sheet joints are touch fitted and fastener heads and joints stopped in accordance with the GIB® Site Guide.

Fastening the Ecoply®

Fasteners

Fasten with 50 x 2.8 mm galvanised or stainless steel flat head nails for direct fix or 60 x 2.8 mm over cavity battens. Place fasteners no less than 7 mm from sheet edges.

Fasteners for H3.2 CCA treated Ecoply

Where fasteners are in contact with H3.2 CCA treated timber or plywood, fasteners shall be a minimum of hot dip galvanised.

In certain circumstances stainless steel fasteners may be required. Refer to section 4 of NZS3604 for these circumstances.

Refer to Table 8 for further fastener selection advice.

Where stainless steel nails are required, annular grooved nails must be used.

Fastening centres

Fasteners are placed at 150 mm centres around the perimeter of each sheet and 300 mm centres to intermediate studs.

Fastening to cavity battens

The plywood side of the brace element may be fixed over cavity battens.

The cavity battens must be a minimum of 40 x 20 mm nailed staggered formation at 150 mm centres to studs around the perimeter of the brace element, and nailed to the intermediate studs within the element at 300 mm centres, with 50 mm x 2.8 mm flat head galvanised or annular grooved stainless steel nails.

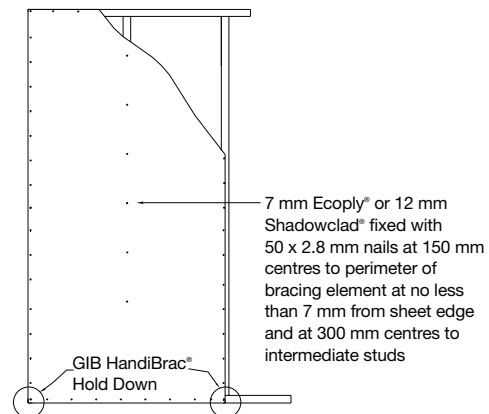

Ecoply® Bracing Systems are designed to meet the requirements of the NZBC and have been tested and analysed using the P21 method referenced in NZS3604 listed as an acceptable solution B1/AS1 Structure. Testing was carried out using Ecoply, Shadowclad and Laserframe MSG8 timber framing manufactured by Carter Holt Harvey Limited trading as Carter Holt Harvey Woodproducts New Zealand, and GIB® products manufactured by Winstone Wallboards Ltd. Substituting materials may compromise performance of the system. GIB® and GIB HandiBrac® are registered trade marks of Fletcher Building Holdings Ltd.

Fastening the GIB® Plasterboard

Fasteners

32 mm x 6 g GIB® Grabber® Screws or 35 mm GIB® Nails

Fastening centres

Fasten 50, 100 and 150 mm from each corner and 150 mm thereafter around the perimeter of the bracing element. For vertical fixing place fasteners at 300 mm centres at intermediate sheet joints. For horizontal fixing place single fasteners in the tapered edge where sheets cross studs.

Place fasteners 12 mm from paper bound edges and 18 mm from cut sheet edges. GIB® plasterboard must be treated in every respect in accordance with relevant GIB® literature.

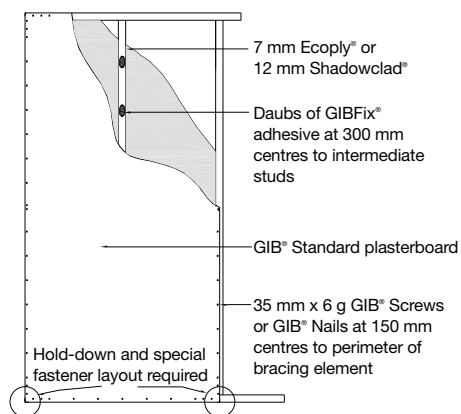

Ecoply® Bracing Systems are designed to meet the requirements of the NZBC and have been tested and analysed using the P21 method referenced in NZ3604 listed as an acceptable solution B1/AS1 Structure. Testing was carried out using Ecoply, Shadowclad and Laserframe MSG8 timber framing manufactured by Carter Holt Harvey Limited trading as Carter Holt Harvey Woodproducts New Zealand, and GIB® products manufactured by Winstone Wallboards Ltd. Substituting materials may compromise performance of the system. GIB® and GIB HandiBrac® are registered trade marks of Fletcher Building Holdings Ltd.